

Section 11: Linear Mechanical Equations

We can consider the application of an external driving force (with or without damping). Assume a time dependent force $f(t)$ is applied to the system. The ODE governing displacement becomes

$$m \frac{d^2 x}{dt^2} = -\beta \frac{dx}{dt} - kx + f(t), \quad \beta \geq 0.$$

Divide out m and let $F(t) = f(t)/m$ to obtain the nonhomogeneous equation

$$\frac{d^2 x}{dt^2} + 2\lambda \frac{dx}{dt} + \omega^2 x = F(t)$$

Forced Undamped Motion and Resonance

Consider the case $F(t) = F_0 \cos(\gamma t)$ or $F(t) = F_0 \sin(\gamma t)$, and $\lambda = 0$.
Two cases arise

$$(1) \quad \gamma \neq \omega, \quad \text{and} \quad (2) \quad \gamma = \omega.$$

Taking the sine case, the DE is

$$x'' + \omega^2 x = F_0 \sin(\gamma t)$$

with complementary solution

$$x_c = c_1 \cos(\omega t) + c_2 \sin(\omega t).$$

$$x'' + \omega^2 x = F_0 \sin(\gamma t)$$

Suppose $\gamma \neq \omega$

Note that

$$x_c = c_1 \cos(\omega t) + c_2 \sin(\omega t).$$

Using the method of undetermined coefficients, the **first guess** to the particular solution is

$$x_p = A \cos(\gamma t) + B \sin(\gamma t) \quad \text{will this form work?}$$

Yes it will.

The displacement x will look like

$$x = c_1 \cos(\omega t) + c_2 \sin(\omega t) + A \cos(\gamma t) + B \sin(\gamma t)$$

$$x'' + \omega^2 x = F_0 \sin(\gamma t)$$

Suppose $\gamma = \omega$

Note that

$$x_c = c_1 \cos(\omega t) + c_2 \sin(\omega t).$$

Using the method of undetermined coefficients, the **first guess** to the particular solution is

$$x_p = A \cos(\gamma t) + B \sin(\gamma t) = A \cos(\omega t) + B \sin(\omega t)$$

This won't work!

$$x_p = At \cos(\omega t) + Bt \sin(\omega t) \text{ this is correct}$$

In this case

$$x = c_1 \cos(\omega t) + c_2 \sin(\omega t) + At \cos(\omega t) + Bt \sin(\omega t)$$

Forced Undamped Motion and Resonance

For $F(t) = F_0 \sin(\gamma t)$ starting from rest at equilibrium:

$$\text{Case (1): } x'' + \omega^2 x = F_0 \sin(\gamma t), \quad x(0) = 0, \quad x'(0) = 0$$

$$x(t) = \frac{F_0}{\omega^2 - \gamma^2} \left(\sin(\gamma t) - \frac{\gamma}{\omega} \sin(\omega t) \right)$$

If $\gamma \approx \omega$, the amplitude of motion could be rather large!

Pure Resonance

Case (2): $x'' + \omega^2 x = F_0 \sin(\omega t)$, $x(0) = 0$, $x'(0) = 0$

$$x(t) = \frac{F_0}{2\omega^2} \sin(\omega t) - \frac{F_0}{2\omega} t \cos(\omega t)$$

Note that the amplitude, α , of the second term is a function of t :

$$\alpha(t) = \frac{F_0 t}{2\omega}$$

which grows without bound!

► Forced Motion and Resonance Applet

Choose "Elongation diagram" to see a plot of displacement. Try exciting frequencies close to ω .

Section 12: LRC Series Circuits

Potential Drops Across Components:

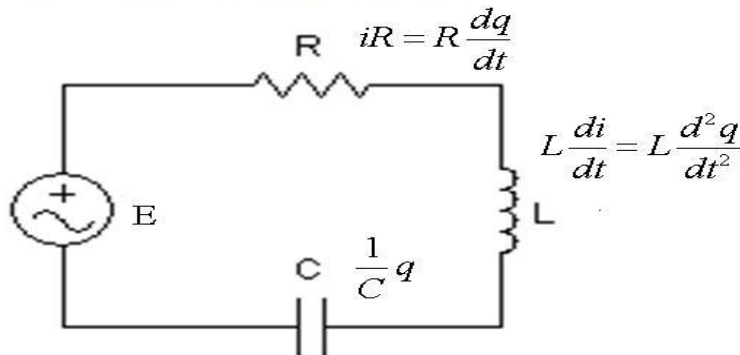

Figure: Kirchhoff's Law: The charge q on the capacitor satisfies $Lq'' + Rq' + \frac{1}{C}q = E(t)$.

This is a second order, linear, constant coefficient nonhomogeneous (if $E \neq 0$) equation.

LRC Series Circuit (Free Electrical Vibrations)

$$L \frac{d^2 q}{dt^2} + R \frac{dq}{dt} + \frac{1}{C} q = 0$$

If the applied force $E(t) = 0$, then the **electrical vibrations** of the circuit are said to be **free**. These are categorized as

overdamped if

$$R^2 - 4L/C > 0,$$

critically damped if

$$R^2 - 4L/C = 0,$$

underdamped if

$$R^2 - 4L/C < 0.$$

Handwritten notes:
← 2 real roots
← one real root
↑ complex conjugate roots

Steady and Transient States

Given a nonzero applied voltage $E(t)$, we obtain an IVP with nonhomogeneous ODE for the charge q

$$Lq'' + Rq' + \frac{1}{C}q = E(t), \quad q(0) = q_0, \quad q'(0) = i_0.$$

From our basic theory of linear equations we know that the solution will take the form

$$q(t) = q_c(t) + q_p(t).$$

The function of q_c is influenced by the initial state (q_0 and i_0) and will decay exponentially as $t \rightarrow \infty$. Hence q_c is called the **transient state charge** of the system.

Steady and Transient States

Given a nonzero applied voltage $E(t)$, we obtain an IVP with nonhomogeneous ODE for the charge q

$$Lq'' + Rq' + \frac{1}{C}q = E(t), \quad q(0) = q_0, \quad q'(0) = i_0.$$

From our basic theory of linear equations we know that the solution will take the form

$$q(t) = q_c(t) + q_p(t).$$

The function q_p is independent of the initial state but depends on the characteristics of the circuit (L , R , and C) and the applied voltage E . q_p is called the **steady state charge** of the system.

Example

An LRC series circuit has inductance 0.5 h, resistance 10 ohms, and capacitance $4 \cdot 10^{-3}$ f. Find the steady state current of the system if the applied force is $E(t) = 5 \cos(10t)$.

We want to find the steady state current.

This is $\frac{dq}{dt}$, i.e. i .

The ODE is $Lq'' + Rq' + \frac{1}{C}q = E(t)$

Here $L = \frac{1}{2}$, $R = 10$, $C = 4 \cdot 10^{-3}$, $E(t) = 5 \cos(10t)$

Note $\frac{1}{C} = \frac{1}{4 \cdot 10^{-3}} = \frac{10^3}{4} = 250$

The ODE is $\frac{1}{2} q'' + 10q' + 250q = 5 \cos(10t)$

In standard form

$$q'' + 20q' + 500q = 10 \cos(10t).$$

Look for q_c : The characteristic equation is

$$r^2 + 20r + 500 = 0$$

$$r^2 + 20r + 100 - 100 + 500 = 0$$

$$(r+10)^2 + 400 = 0$$

$$(r+10)^2 = -400$$

$$r+10 = \pm 20i \Rightarrow r = -10 \pm 20i$$

$$g_c = c_1 e^{-10t} \cos(20t) + c_2 e^{-10t} \sin(20t)$$

Now solve for g_p . Using undetermined coefficients from $g(t) = 10 \cos(10t)$, let

$$g_p = A \cos(10t) + B \sin(10t)$$

Substitute $g_p' = -10A \sin(10t) + 10B \cos(10t)$

$$g_p'' = -100A \cos(10t) - 100B \sin(10t)$$

$$g_p'' + 20g_p' + 500g_p = 10 \cos(10t)$$

$$-100A \cos(10t) - 100B \sin(10t) + 20 \left(-10A \sin(10t) + 10B \cos(10t) \right)$$

$$+ 500 \left(A \cos(10t) + B \sin(10t) \right) = 10 \cos(10t)$$

Collect $\cos(10t)$ and $\sin(10t)$ terms

$$\cos(10t) \left(400A + 200B \right) + \sin(10t) \left(-200A + 400B \right)$$

$$= 10 \cos(10t) + 0 \cdot \sin(10t)$$

Matching gives

$$400A + 200B = 10$$

$$-200A + 400B = 0$$

$$400A + 200B = 10$$

$$-400A + 800B = 0$$

$$1000B = 10 \Rightarrow B = \frac{10}{1000} = \frac{1}{100}$$

$$-200A + 400B = 0 \Rightarrow 200A = 400B$$

$$A = 2B$$

$$A = 2\left(\frac{1}{100}\right) = \frac{2}{100}$$

$$\text{So } i_p = 0.02 \cos(10t) + 0.01 \sin(10t)$$

The steady state current

$$\frac{d i_p}{d t} = -10(0.02) \sin(10t) + 10(0.01) \cos(10t)$$

$$i_p = 0.1 \cos(10t) - 0.2 \sin(10t)$$